

Manual
for the Installation,
Use and Maintenance
„Söll-GlideLoc“ fall arrest system
of
Rotary-Exit-Section

without footrest Part No. 21814

with footrest Part No. 10558

**in conjunction with
aluminium Y-spar and
aluminium twin ladder**

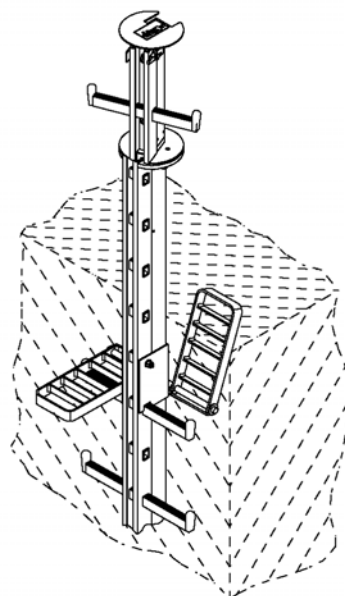

date: 26.08.2008
SE 7



Table of Contents

A	General	3
B	Installation	4
C	Inspection and approval	13
D	Bolt connections/Securing of bolts	14
E	Use of the rotary-exit-section	15
F	Maintenance	19
G	Check List	21

These instructions are protected by copyright!

They may not be reproduced and distributed in any ways/
by any means without prior written consent of the author
according to Articles 16 and 17 of the German Copyright Act.
Sperian Fall Protection Deutschland GmbH & Co. KG
will prosecute any violations against this
under Article 106 of the German Copyright Act.

Notice!
In this issue the following has been changed: address

A General

- A 1. Anyone working with or on SÖLL fall protection systems in accordance with EN 353/part 1 must be familiarized with these instructions prior to using the system. Use which is not in accordance with these instructions constitutes a risk to human life!
- A 2. The operator of the fall protection system must ensure that these instructions are either
- retained in a dry and secure condition at the installation or
 - retained by the operator, whereby he or she must ensure that the user is aware of the storage location of these instructions and that the documents are accessible at all times.
- A 3. If requested, the plant operator must present these instructions to the manufacturer of the fall protection system (Sperian Fall Protection Deutschland GmbH & Co. KG or a dealer authorized by the same).
- A 4. The SÖLL fall protection system must be used in accordance with the instructions for the relevant SÖLL fall arrester.
- A 5. The fitment and use of SÖLL accessories to such fall protection systems must strictly adhere to the relevant instructions for the fitment and use thereof.
- A 6. In case of the use of further personal protective equipment, relevant instructions must be followed.
- A 7. National regulations on accident prevention and use of safety equipment for construction work must be adhered to.
- A 8. Söll fall protection systems may only be fitted and used with original Söll components/elements or parts. The combination with non-original components/elements or parts may influence the safety of SÖLL fall protection systems. In such cases, Sperian Fall Protection Deutschland GmbH & Co. KG and the dealer authorized by the same refuse to accept product liability. In addition, such systems are not properly approved and authorized since SÖLL fall protection systems are tested, approved and authorized as complete systems. Full liability will therefore rest with the operator.
- A 9. The check list (see Section G) must be fully and correctly compiled by the chief engineer of the installing company by means of an indelible pen.
- A 10. Before and during the use of the installed fall protection system, the system must be visibly inspected to ensure that it is operating properly.
- A 11. The system has been tested and approved by "Stelle 0158: EXAM BBG Prüf- und Zertifizier GmbH, Zertifizierungsstelle, Dinnendahlstraße 9, 44809 Bochum.

B Installation

B 1. The assembly kit consists of:

- 1 rotary-exit-section (rotary section with integrated reinforcement profile)
- 1 ladder segment mounted on the rotary-exit-section in accordance with specifications (length/type)
- if applicable: 1 footrest with individually hinged and folding footrest halves
- 2 mounting brackets, (we recommend the use of brackets P/N 14673)

The bolts for wall anchorage must be chosen to suit the relevant under structure and if needed must be design proven.

Bolt connections must be secured against loosening. Refer to section D „Bolt connections/ securing of bolts“.

B 2. Equipment required for easy fitting:

- 2 open wrenches, SW 19
- 1 open wrench, SW 10
- 1 open wrench for wall bolts, according to requirements,
- 1 open wrench, SW 13
- 1 allen key 10 mm
- 1 hand drill
- 1 drill bit 13 mm
- 2 Söll compact fall arresters
- 2 full body harnesses according EN 361
- 1 roller extension (for a max. load of 20 kg),
purchase order no. 17563, for lifting and lowering of ladder sections
- 1 rope for cantilever arm, maximum diameter 12 mm, length as required
- 1 toolbox
- 2 walkie-talkies
- 1 deflection sheave

Min. 1 additional safety lanyard according to EN 354/355 with energy absorber for each person to protect the mounting person against falls from height during the installation.

B 3. Personnel required for installation:

two persons

B 4. Components must be handled carefully. They must not be thrown.

B 5. Before installation, components must be cleaned from dirt - in particular on connecting surfaces. They must not come into contact with cement, mortar or similar substances. Remnants of mortar must be wiped off immediately. Especially the sliding surfaces for the fall arrester on the inside and outside of the guide-rail must be free of dirt.

B 6. Damaged parts may neither be used nor repaired but must be replaced by new ones.

B 7. Minimum bolt dimensions for the installation of Söll fall protection system on existing structures:

The minimum bolt size for fixing brackets is M 12. When ordering brackets, ensure the holes will accommodate the chosen bolt size.

We specifically stress that only those dowels may be used which are permitted by site inspection engineers.

Important:

The rotary exit unit shall be installed using at least 2 mounting brackets.

B 8. Caution:

By using a mounting distance of 1120 mm, the installation of the ladder may be carried out without a scaffold. When using a greater mounting distance, an installation scaffold is required. The person installing the equipment uses a full-body harness and a fall arrester. In order to be protected against a fall from a height where the fall arrester slips from the rail, or the not completely installed ladder bends backwards, the installer must always use a safety lanyard with shock absorber in accordance to EN 354/355 or a retaining rope in accordance with EN 358 (see Fig. 1).

Warning!

The proper functioning of the fall arrester can only be guaranteed in that part of the guiding rail that is located between gated end stops as well as during proper use.

Installation or dismounting of the fall arrester on the guiding rail as well as moving beyond the gated end stop may only be done in a safe position (e.g., firm ground, safe platform).

Important:

*During the installation procedure **never** let the fall arrester pass above the any mounting bracket that has not been properly mounted and secured to the support structure.*

Fig. 1

B 9. Erection staff can during the installation secure themselves by using:

- Safety lanyard (acc. to EN 354/355) connected to the center rail to the ladder under the highest situated properly secured mounting bracket
- The carabiner of a safety lanyard (EN 354/355) is connected to a mounting bracket
- Support lanyard (EN 358) routed around the centre rail of the ladder
- The use of an external anchorage point

Fig. 1

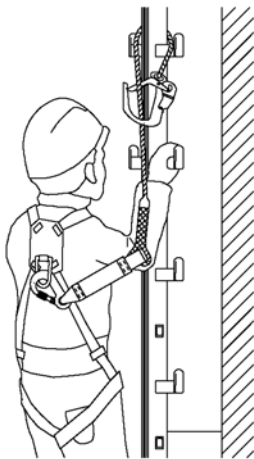

EN 354/355

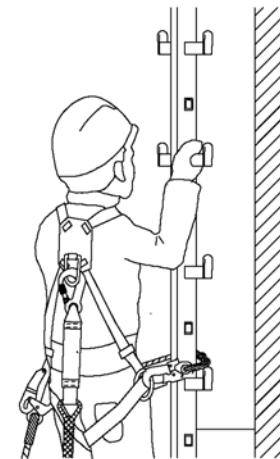
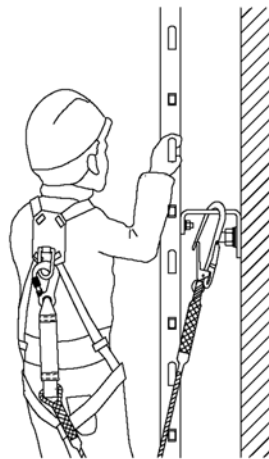

EN 358

Warning:

Never use the side stringer of a twin ladder for anchorage purposes!

Fig. 2a/b

B 10. Prior to fitting the rotary-exit-section to the building, the brackets (2.0; at least two) are loosely fitted to the guide rail (1.0) at a distance between 1.680 mm (max.) and 1.120 mm (min.).

Pay attention to:

- any screw connection has to be secured against unintended opening
- the reinforcement profile should be mounted to the rail/ladder profile (1.0) at intervals not exceeding 560 mm
- when a rotary in mounted to a Y-spar ladder the two top rungs of that ladder shall be removed
- along the total length of the reinforcement profile no ladder joints are allowed
- the reinforcement profile must be in one section only

Fig. 2a

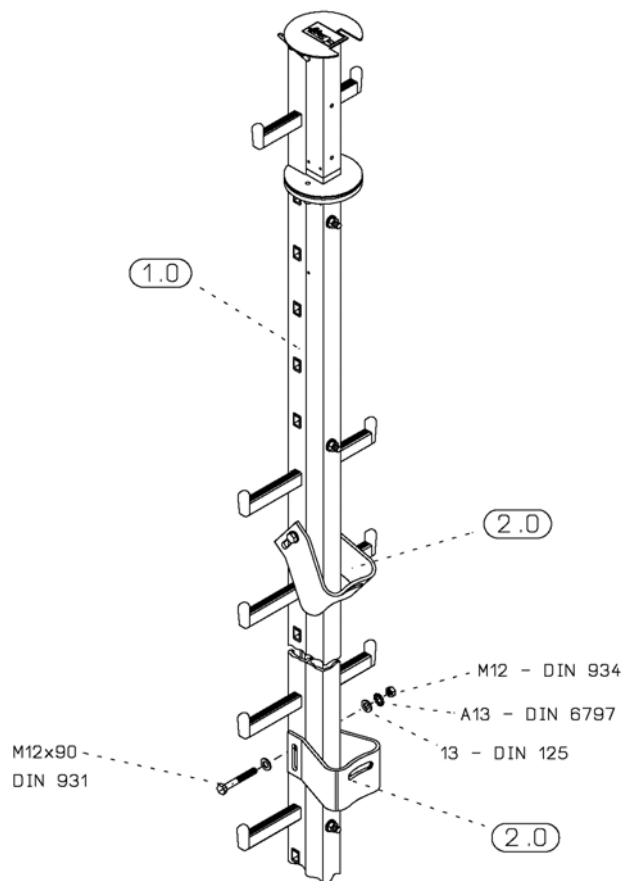
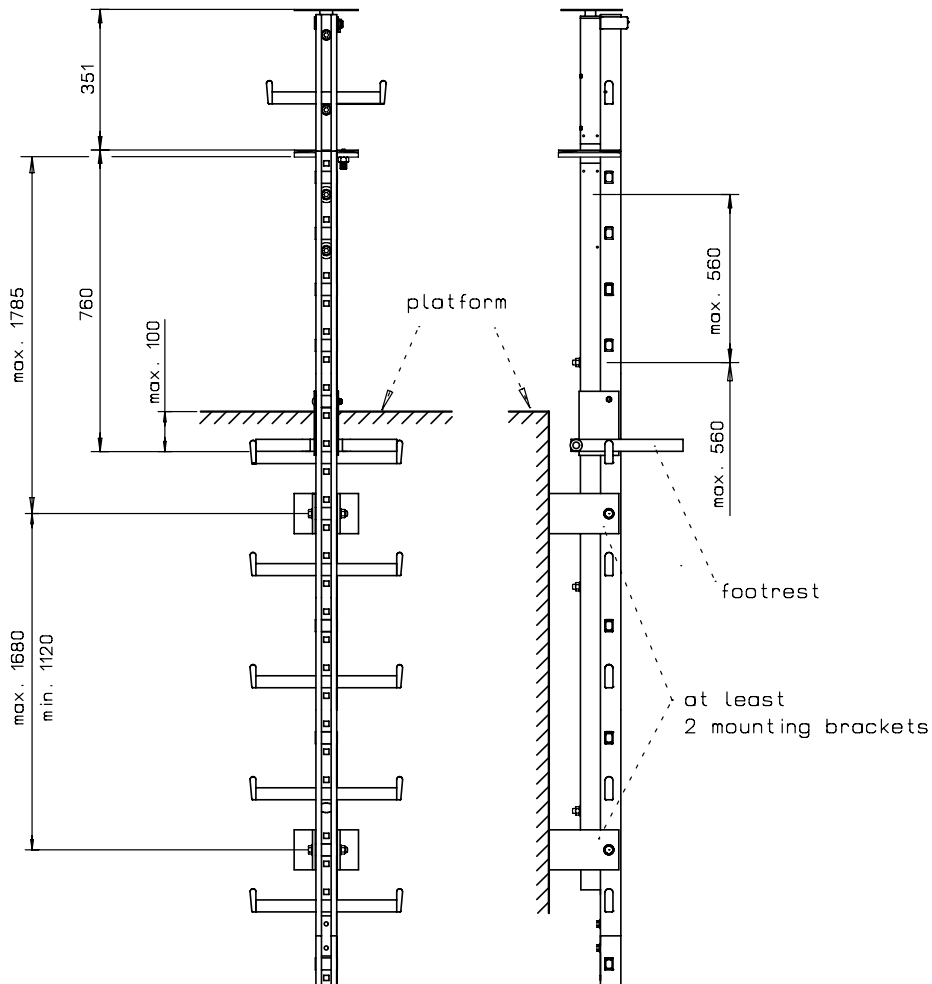

Fig. 2b



Attention:

The rotary exit section must be attached to the building construction with at least 2 brackets. The distance between the brackets shall be min. 1120 mm and max. 1680 mm. The distance between the lower edge of the horizontal turn table and the upper bracket may not exceed 1785 mm.

Fig. 3

B 11. Lean the ladder section with the integrated rotary-exit-section against the mast structure and push vertically into the lower ladder segment which has already been fixed. Fix the bracket to the structure using wall fastening bolts. Using the elongated holes, adjust the ladder section so that it is perpendicular in the bracket and tighten. Also tighten the cross bolt.

Fig. 3

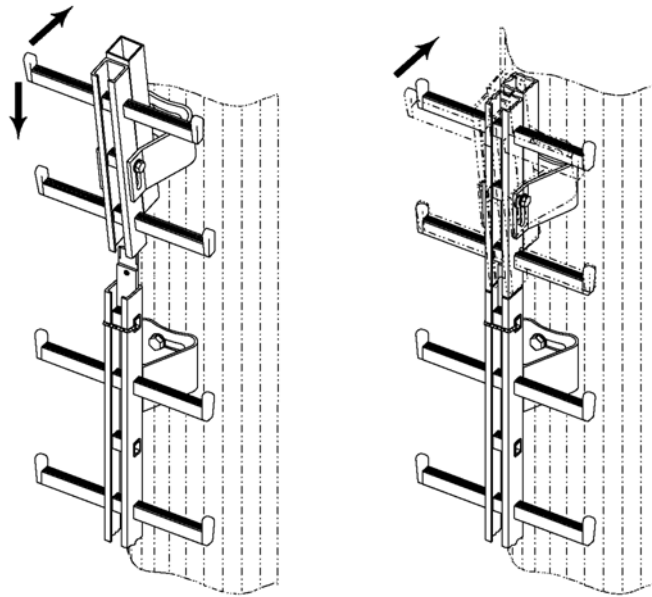

B 12. Torque ranges:

When tightening mounting screws in **steel quality 8.8** used in combination with tooth lock washers the following tightening torque range is recommended:

Screw size:	M 10	M 12	M 16	M 20
	20 Nm	25 Nm	60 Nm	120 Nm

When tightening mounting screws in **stainless steel quality 1.4571** in combination with Söll supplied auto-locking nuts (DIN 985) the following torque range is recommended:

Screw size:	M 10	M 12	M 16	M 20
	40 Nm	45 Nm	85 Nm	150 Nm

When tightening the **toothed head screw** used for rail connectors in aluminium ladders we recommended a tightening torque of **20 Nm**.

B 13. Minimum Gap Width:

Mounting recommendations:

- Under positive ambient temperature, gap width 2 mm
- Under negative ambient temperature, gap width 3 mm
- During re-examination, make sure that the maximum gap width of 5 mm is not exceeded (independently from the ambient temperature)

Fig. 4

B 14. During the installation ensure that:

- ladders are **vertical** in the **X-direction**
- ladder **inclination** in the **Y-direction** should be within the range **0°-15°**
- ladder joints are flush and properly aligned

Fig. 4

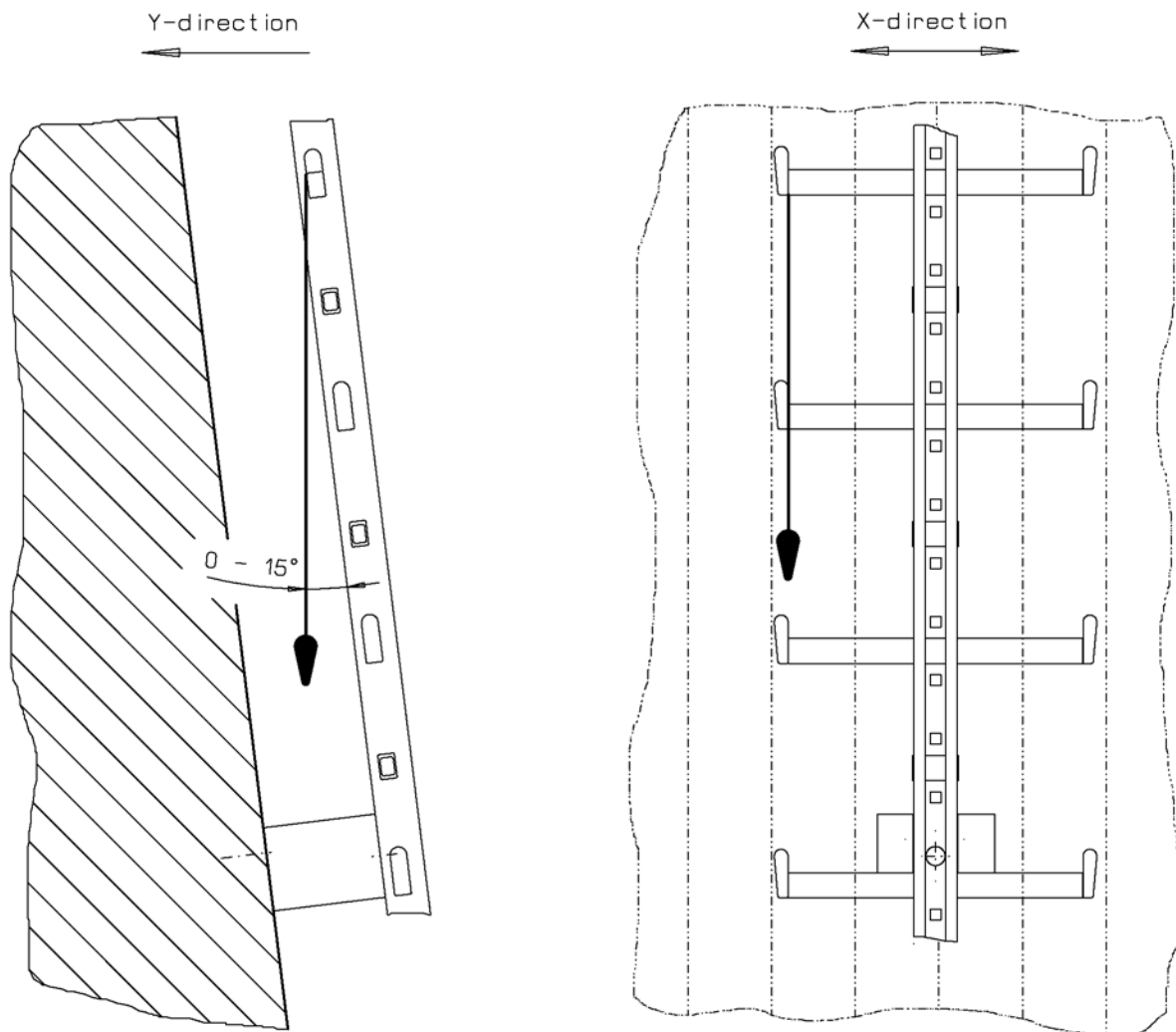
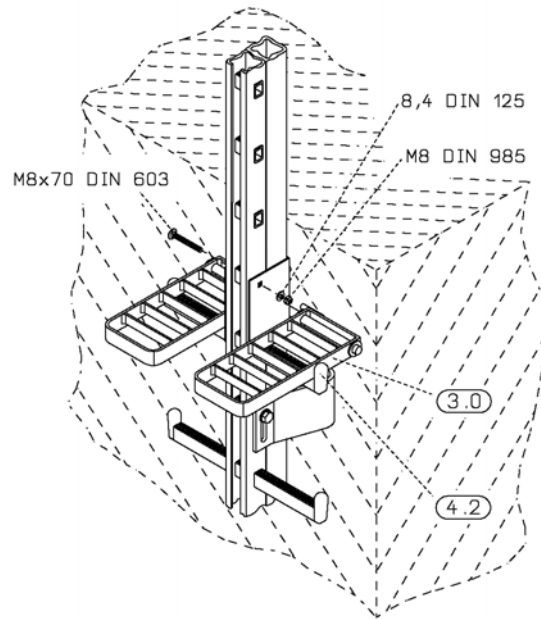

Fig. 5

- B 15. If included in the parts delivered, attach the footrest (3.0; Part No. 11392) in such a manner that when folded down, the footrest rests horizontally on the uppermost rung (4.2).

Fig. 5



C Inspection and approval

Fig. 6

At the "OK to climb" inspection the following details have to be considered:

- The rotary exit section shall be installed using at least 2 mounting brackets
- The ladder joints are flush and properly aligned
- In the **X-direction** ladder section shall be **vertical** (see fig. 6)
- In the **Y-direction** the angle between the vertical line and the ladder sections may range from **0° bis 15°**. (see fig. 6)
- Always check the following screw connections:
 - ➔ mounting bracket to support structure
 - ➔ mounting bracket to ladder rail
 - ➔ connections between ladder sections
 - ➔ Rotary section to ladder profile
 - ➔ attachment of end stops to rail
- all screw connections have to be properly tightened and secured against unintended opening (refer to section E)
- the stop lever in end stops must automatically fall into lock position.
- The instructions for the installation of ladders resp. guide rails as given in S4, S5 and S6 are duly followed.

Fig. 6

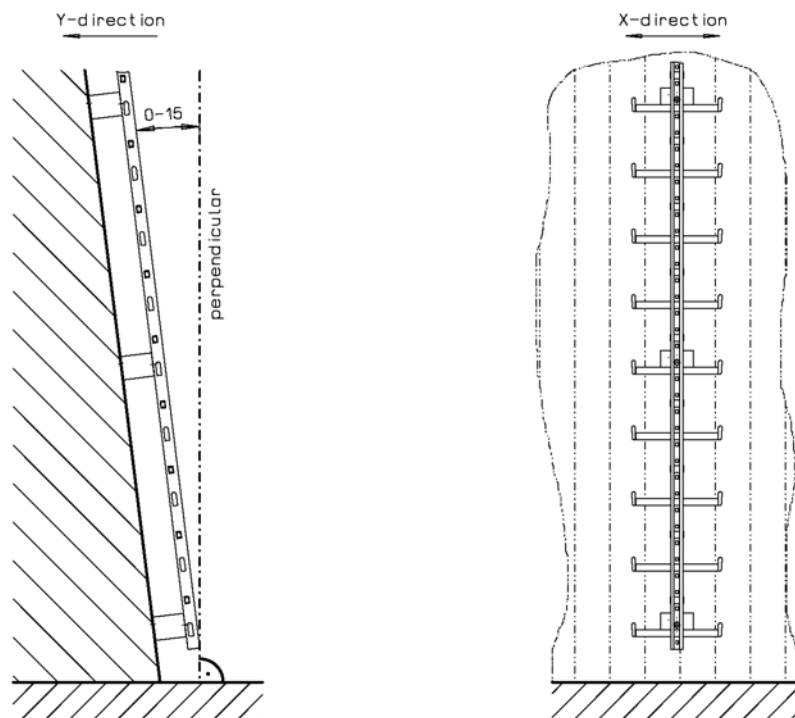

D Bolt connections/Securing of bolts

At use of hot dip galvanised screws the tooth washer ensures satisfactory securing of the screw/nut connection.

At use of stainless steel screws self-locking nuts (nyloc or similar) shall be used.

At aluminium-ladder joints the supplied tooth washers provide secure screw/nut locking.

E Use of the rotary-exit-section

E 1. Exit to a platform and removal of the fall arrester from the exit unit:

Prerequisite:

The guide rail (1.2) in the rotary section (1.1) must be properly aligned with the ladder guide rail (4.1).

Fig.7

- a) should the above condition not apply, lift to release the rotary section and rotate it into the correct position.

Advise:

- during rotation of the rotary section, do not keep it lifted
- The stop pin (9.0) must stop the rotary section when it has reached the correct position with the rail in ladder (4.1) and in the rotary section (1.2).

Fig. 7

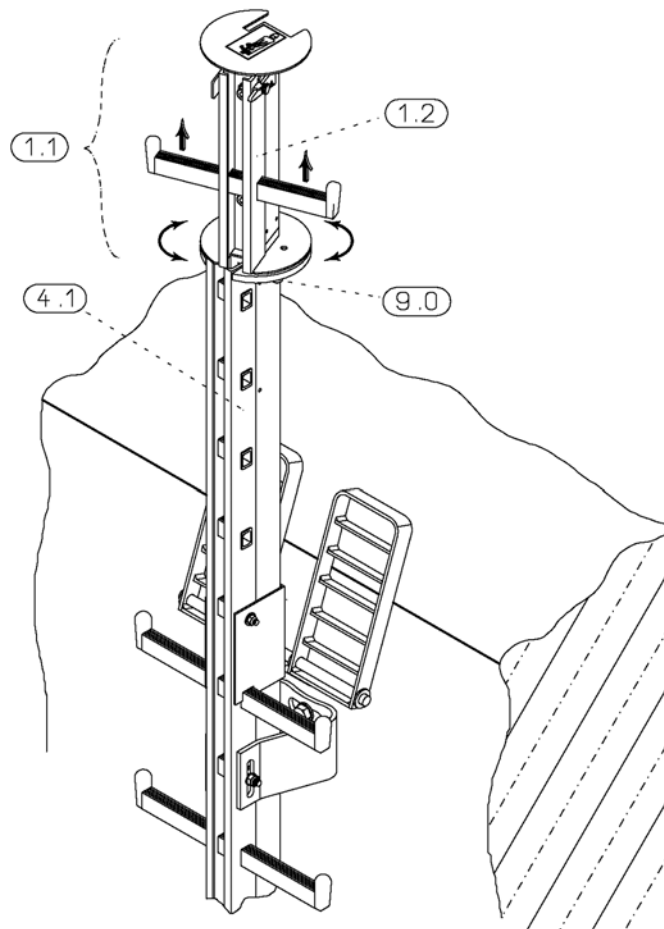

Fig.8

- b) When the two rail sections (1.2)(4.1) are aligned move the fall arrester (5.0) into the rotary section (1.1).

Recommendation:

Should the unit (3.0) be equipped with foldable foot rests, kick those into fold-down position.

Use the ladder rung (1.3) to lift the rotary section (1.1) and release it from its stop pin (9.0). Rotate the section 180° and follow it with your fall arrester so that you can transfer to the platform. After rotating the section 180° it should again lock into its stop pin (9.0). Remove the fall arrester from the section whilst ensuring that you are protected against risks of falling.

Notice:

- When rotating the rotary section, do **not** lift it.
- The rotary section can be rotated clock wise and anti clock wise.
- When rotating the rotary section, ensure that the locking catch of the fall arrester is secured against a notch or stop (1.3) block in the rail.
- The guide rail of the ladder (1.4) should when the exit unit (1.1) is rotated be closed for exiting the from rail!
- **It should not be possible to let a fall arrester exit from the ladder guide rail when the exit unit is rotated.**

Fig. 8

Fig.9

- c) Open the locking gate (1.5) of the upper end stop (1.4) and move the fall arrester (5.0) out of the rotary exit unit (1.1).

Notice:

The locking gate (1.5) must automatically go back into locked position when released.

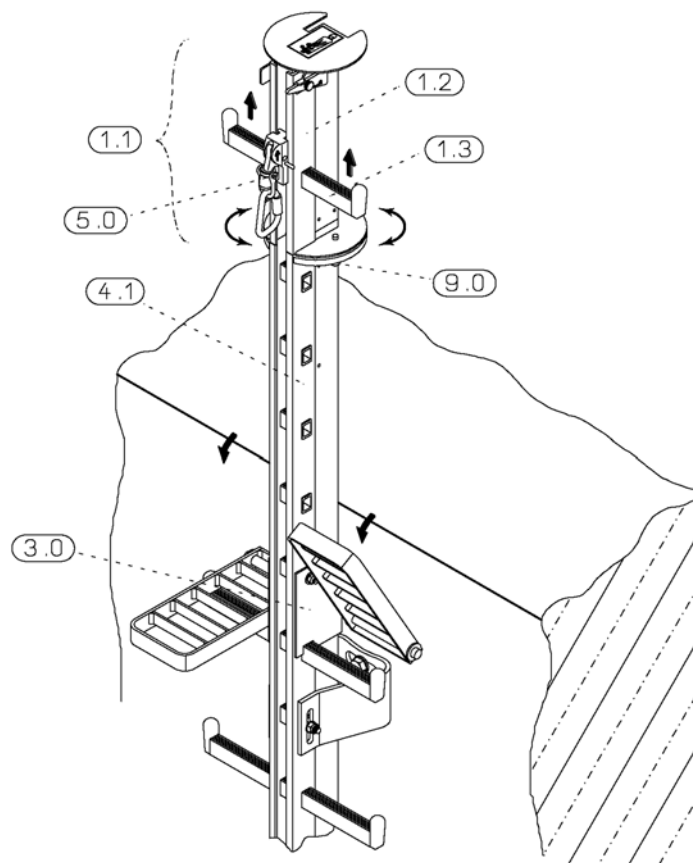
Important:

When disconnecting from the fall arrest system, ensure that an other means of protection against fall is achieved.

Fig. 9

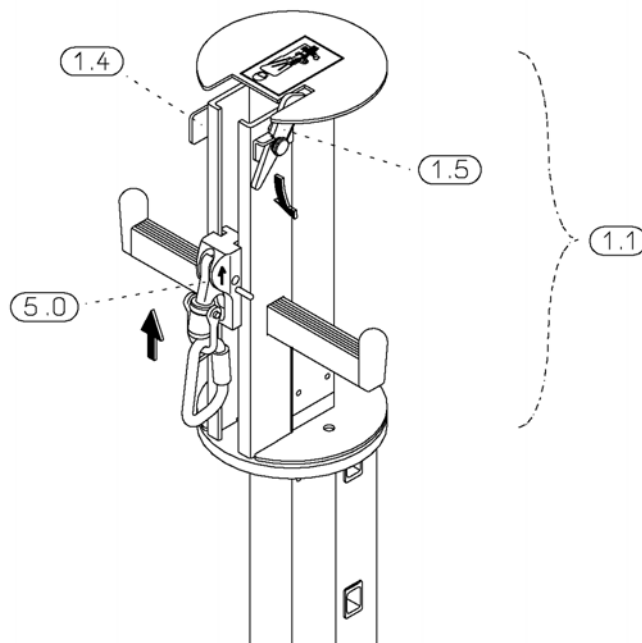

Fig. 10**E 2. Connecting the fall arrester into the exit unit from the roof/platform:**

Rotate the exit unit (1.1) in such a position that the fall arrester can be inserted into the rotary rail section. Place the fall arrester (5.0) in the rotary rail section (1.2) of the exit unit (1.1). Ensure that:

- the engraved direction arrow of the fall arrester points upwards
- the side stop pin (5.1) of the fall arrester is on its right side

Note:

The locking gate (1.5) of the end stop must automatically close when being released.

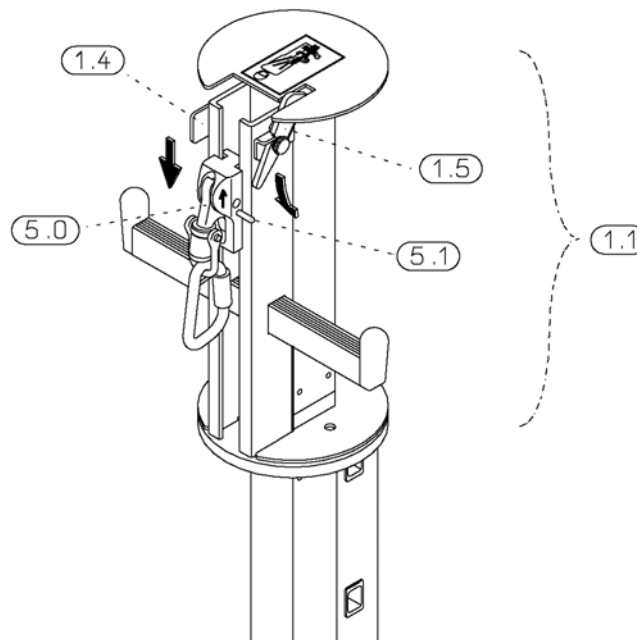
Fig. 10**E 3. Descending from the upper roof/platform**

Lift the head of the rotary exit unit to unlock it. Turn the rotary section 180° so that its rail section (1.2) is aligned with the guide rail of the ladder (4.1) and the rotary section locks into position. Move over to the ladder system (a rung or its foldable platform (3.0) if available). Let the fall arrester slide out of the rotary section (1.1) downwards and into the guide rail of the ladder (4.0) descend.

F Maintenance

Notice:

Do not use the rotary exit unit should any doubt exist as to its safe and proper functioning! Should the unit not be in perfect working order – close the system for further use. Do not use it until a competent person has declared the system „safe for use“.

Repairs or modifications of the rotary exit unit may not take place!

A unit that may have been damaged because of a fall, needs to be replaced.

Fig. 11

- F 1. A rotary exit unit shall as need arises, however at least once per year, be inspected by a competent person authorized by the manufacturer.

Competent person is a:

person who thanks to his education and experience in the field of personal protective equipment against falls from height has sufficient knowledge about applicable state and local safety regulations, applicable standards (e.g. EN-standards) and is thus capable and thus authorized by Söll of judging the correct status and use of systems and products against falls from height.

- F 2. Every time the system is used, visually inspect and check that the rotary exit unit and its components do function properly.
- F 3. Always ensure that the rotary exit unit as well as other system components be free from dirt.
- F 4. Ensure that all screw connections are properly secured against unintended loosening. Refer to Section D of this instruction.

- F 5. The rotary section (1.1) should be possible to turn without the use of excessive force.
- F 6. The stop pins (9.0) must prevent the rotary unit (1.1) from turning when
- the rotary unit is in neutral position (when the guide rails of the ladder (4.1) and the rotary unit (1.2) are aligned
 - and after turning the unit 180°
- F 7. The locking gate (1.5) of the upper end stop (1.4) must automatically go back into closed position when released and hereby prevent unintended exiting of a fall arrester from the system.

Fig. 11

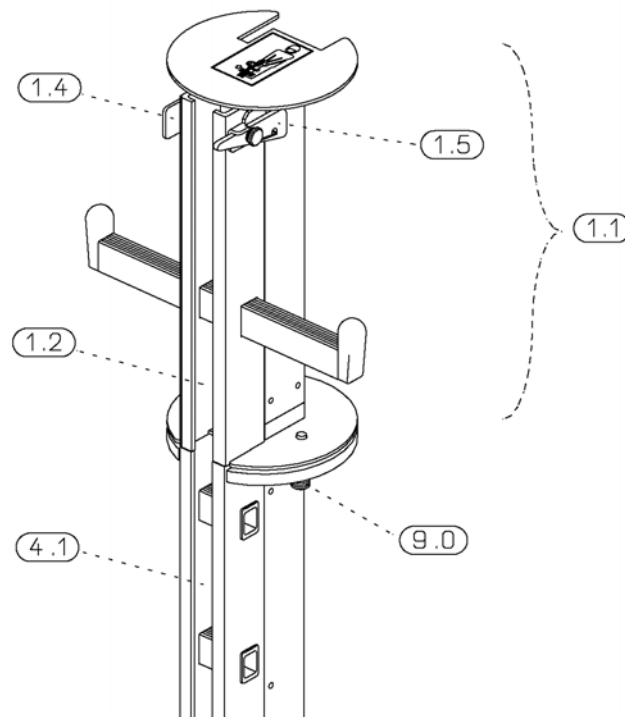

G Check List for the Inspection and Approval of Söll „GlideLoc“ fall arrest system for rotary-exit-section

without footrest Part No. 21814
 with footrest Part No. 10558

The check list on pages 21 and 22 must be fully and correctly compiled by the chief engineer of the installing company by means of an indelible pen. He is responsible for the correctness of all the information provided therein. Any checkpoint with a "No" remark must be explained under the defects, irregularities on page 22.

Control Activity	Remarks	
	(please cross)	
	yes	no
• The fixing distance of the spar reinforcement bolts spar guide rail is a maximum of 560 mm (in accordance with section B 10).	<input type="checkbox"/>	<input type="checkbox"/>
• The rotary exit section shall be attached to the building structure by means of at least two mounting brackets, located min. 1120 mm and max. 1680 mm from each other (please refer to sect. B 10).	<input type="checkbox"/>	<input type="checkbox"/>
• The reinforced central spar is equipped with a continuous guide rail (corresponds to section B 10).	<input type="checkbox"/>	<input type="checkbox"/>
• The distance between the lower edge of the horizontal turn table and the upper bracket may not exceed 1785 mm (see Sect. B 10).	<input type="checkbox"/>	<input type="checkbox"/>
• The gap width of the rail connections corresponds to Section B13 of these instructions.	<input type="checkbox"/>	<input type="checkbox"/>
• The screw connections between the structure and the fixing elements correspond to Section B7.	<input type="checkbox"/>	<input type="checkbox"/>
• The fixing elements are fitted in accordance with the regulations and all screw connections are tightly secured (correspond to Section B7).	<input type="checkbox"/>	<input type="checkbox"/>
• All bolt connections are secured against loosening in accordance with the regulations.	<input type="checkbox"/>	<input type="checkbox"/>
• The stop gate of the upper end stop functions properly and goes into locked position when released.	<input type="checkbox"/>	<input type="checkbox"/>
• The footrest (if part of the delivery) has been fitted in accordance with the regulations and has been tested with regard to its function.	<input type="checkbox"/>	<input type="checkbox"/>
• The rotary unit is locked from unintended turning when in neutral position (rails in ladder and rotary unit are aligned), as well after it being rotated 180°.	<input type="checkbox"/>	<input type="checkbox"/>
• The rotating section can be turned easily after lifting.	<input type="checkbox"/>	<input type="checkbox"/>
• The rotary exit unit as well as guide rail in ladder are free from dirt.	<input type="checkbox"/>	<input type="checkbox"/>
• Only corrosion-proof fixing elements and screw connections have been used.	<input type="checkbox"/>	<input type="checkbox"/>
• The Söll guided-type fall arrester can only be inserted into the rotary-exit-section in the effective direction in which it travels.	<input type="checkbox"/>	<input type="checkbox"/>
• Test climb carried out.	<input type="checkbox"/>	<input type="checkbox"/>
• No defects or shortcomings were found.	<input type="checkbox"/>	<input type="checkbox"/>
• These instructions were handed over to the operator.	<input type="checkbox"/>	<input type="checkbox"/>
• Only original Sperian Fall Protection Deutschland GmbH & Co. KG, Engineering components were used.	<input type="checkbox"/>	<input type="checkbox"/>

