



F Care

- F 1. The entire fall arrester is to be washed with water and dried using an absorbent cloth. Do not clean it with trichloroethane containing quick-cleaning agents, thinning agents or cold-cleaning agents. **Do not use grease.**
- F 2. Rollers (fig. 7 detail 1.3) are equipped with friction bearings and are greased in the factory.
- F 3. Swivelling shackles (fig. 7 detail 3.0) are to be lubricated slightly.
- F 4. Oil the knurled sleeve (fig. 7 detail 4.1) if required.
- F 5. **Attention!**
Do not expose the fall arrester to chemicals.

G Storage

When storing the fall arrester, it must be clean, as dry as possible and free from dust. It must not be stored in the direct proximity of heat sources.



Instruction for use and maintenance of sliding type fall arrester type Söll-Universal II for use in Söll GlideLoc™ fall arrest systems in accordance with EN 353-1

Part no. 23531/25805

Serial number: _____

Date of manufacture: _____

(The following must be completed by the operator in permanent waterproof ink.)

Date of initial operation: _____

Operator/user: _____

Street: _____

Place: _____

Tel: _____ Fax: _____

Version: 17.01.2011



Table of Content

| | Page |
|--|------|
| A General | 3 |
| B Inspection Before Climbing | 4 |
| C Insertion and Use of the Fall Arrester | 5 |
| D Removal of the Fall Arrester from Guide Rail | 12 |
| E Maintenance | 13 |
| F Care | 20 |
| G Storage | 20 |

These instructions are protected by copyright!

They may not be reproduced and distributed in any ways/ by any means without prior written consent of the author according to Articles 16 and 17 of the German Copyright Act.
 Sperian Fall Protection Deutschland GmbH & Co. KG will prosecute any violations against this under Article 106 of the German Copyright Act.

In this issue the following has been changed:
 Article number page 1 complements

Fig. 7

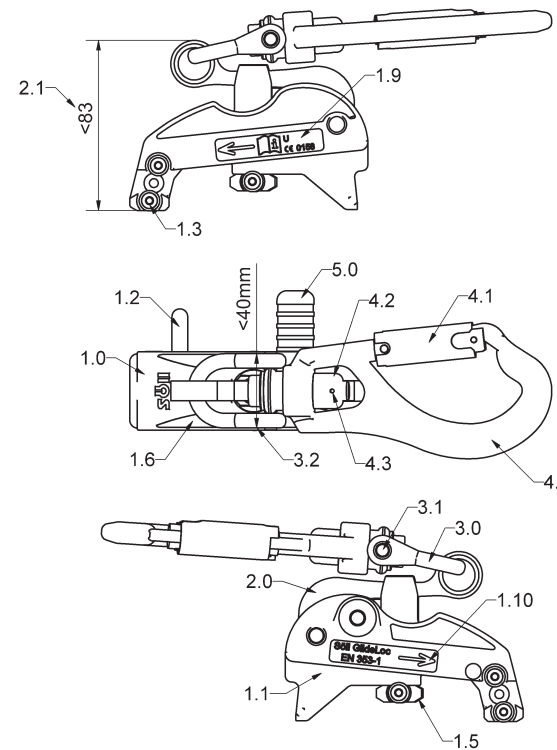

| | |
|---|--|
| Item 3 | |
| rollers (1.3) total of 6 | |
| radial clearance: max. 0.5 mm | |
| rollers (1.3) spin easily (true running) | |
| roller (1.3) are not damaged | |
| Item 4 | |
| Locking axle (1.5) | |
| free of rust | |
| free of dirt, concrete, mortar etc. | |
| can move and rotate freely | |
| is automatically pressed up to the Stopp by the spring | |
| can't rotate when the fall arrester is turned upside down | |
| Item 5 | |
| swivelling shackle (3.0) | |
| Shackle axle (3.1) is riveted | |
| swivelling shackle (3.0) may be easily turned | |
| External dimension of the shackle axle (3.2) max. 40 mm | |
| Rotary shackle is not broken | |
| Rotary shackle (3.0) is not cracked | |

Safety in Action



- B 3. Before and during ascending it should be planned how to effect rescue actions safely and effectively.

C Insertion and Use of the Fall Arrester

Fig.1

Warning

- C 1. The fall arrester, properly used in connection with a full body harness, protects its user during ascent and descent against falls. When working in or along the climbing path, the climber shall always use an additional EN 354 safety lanyard or an EN 358 pole strap to secure himself. The lanyards shall be attached to attachment points (e.g. a ladder mounting bracket) of sufficient strength to withstand the impact of a fall. This requirement also applies for persons stopping at a rest platform. The lanyards shall always be kept as short as possible to minimize the risks of a fall. (see fig. 1)

Fig. 1

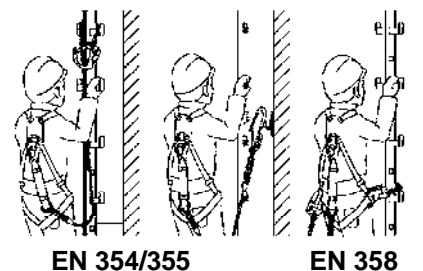

A fall arrester according to EN 353-1 shall be used only by persons who:

- have been trained or are otherwise competent
- are supervised directly by a trained or competent person.

Fig. 2

C.2. Insertion at the start of the ascent:

Insert the fall arrester correctly in the lower end of the rail (6.0) or in the sparing (6.1) which must always be at the height of the waist or lower (**see view "A"**). The locking pin (1.2) protruding from the side must be on the right, the engraved arrow (1.10) on the side of the fall arrester must show to the top.

Together with the end stop (7.0), the safety pin (1.2) prevents the fall arrester from being inserted incorrectly and from accidentally sliding out of the rail.

Fig. 2

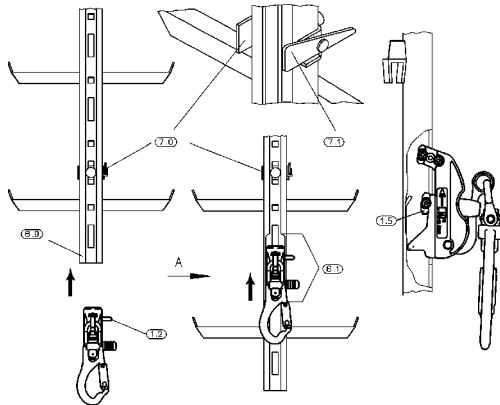

The rollers of the locking axle (1.5) must be located in the guide rail during the use! You may need to push the locking axle through the housing and towards the guide rail from above.

Maintenance checklist, see Fig. 7

| Year | 1 | 2 | 3 | 4 | 5 |
|---|---|---|---|---|---|
| Date | | | | | |
| Competent person | | | | | |
| Signature | | | | | |
| Item 1 | | | | | |
| Body (1.0) | | | | | |
| free of paint, mortar, concrete, dirt etc. | | | | | |
| Identification marking (1.9) on the underside is clearly legible* | | | | | |
| safety pin (1.2) sits firmly and is not bent (check by turning) | | | | | |
| sliding surfaces (1.1) are clean | | | | | |
| Adhesive stickers (1.6) are present and not damaged* | | | | | |
| The engraved arrow (1.10) is in evidence | | | | | |
| Item 2 | | | | | |
| Shock absorber (2.0) | | | | | |
| self-locking with safety pin | | | | | |
| moves easily | | | | | |
| not bent (2.1) | | | | | |

* not relevant to safety

If there is dirt on the inside parts of the fall arrester or if there are defects which involve dismantling, the fall arrester must be sent to the manufacturer (together with the instructions) for inspection, repair and approval.

For reasons of safety, repairs may only be carried out by the manufacturer.

Fig. 6
Example for marking and labelling:

Fig. 6

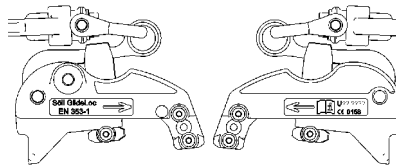

- | | | |
|-------------------|---|--|
| construction year | - | X?? |
| serial number | - | ???? |
| | - | monitoring testing institute |
| | - | advice to read the maintenance check list |
| Söll GlideLoc | - | type denomination of the guided type fall arrester |
| EN 353-1 | - | reference to the European standard |

The test badge must only be affixed if the inspector has not found any defects whatsoever to the fall arrester that might impair its proper functioning.

Fig. 3

- C 3. Open the carabiner hook (4.0) on the fall arrester. With the **self locking carabiner hook** (4.1.) must be **twisted backwards and pushed towards inside**. Insert directly into the anchorage point of the full body harness. The knurled sleeve **must lock automatically after being released**.

Attention!

An unlocked carabiner hook (open knurled sleeve) presents a danger to life.

Fig. 3

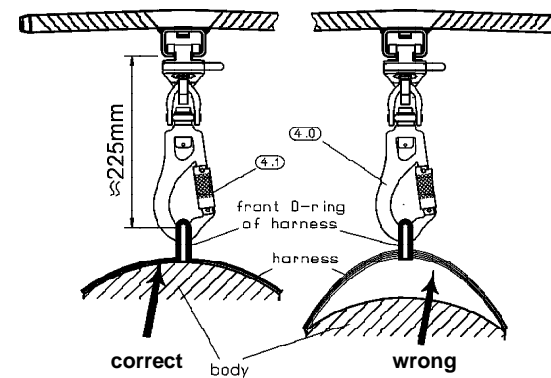

Fig. 4 a/b/c/d/e/f

C 4. Insertion of the fall arrester at any position:

To do this, turn the locking axle (1.5) by 90° out of the travelling position, after having first pulled the locking pin (5.0) and folded the shock absorber (2.0) out.

Insertion into the guide rail is done in the following order:

Insert into the guide rail.

Fig. 4a

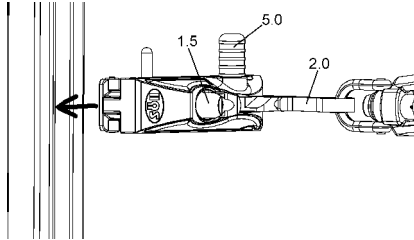

Swing the fall arrester in the running direction.

Fig. 4b

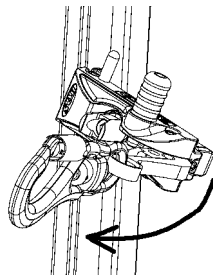

E Maintenance

- E 1. A fall arrester which has arrested a person's fall from a height must not be used again until a competent person has agreed on its further use. If no competent person is available, the fall arrester must be returned to the manufacturer or authorized dealer for inspection **together with these instructions**.
- E 2. Depending on use requirements and operational conditions, the fall arrester must be inspected by a competent person for unimpaired condition to ensure it is in perfect working condition as required, but at least once a year. For reasons of safety the fall arrester may only be repaired by the manufacturer.

A competent person is:

One who is knowledgeable of manufacturer's recommendations and instructions on manufactured components and is capable of identifying existing and predictable hazards in any component of a personal fall protection system and related equipment used in the work environment and who has authorization to take prompt corrective measures to eliminate or control the hazards. He must be familiar with the relevant guidelines, national and international safety regulations and generally acknowledged rules of safety technology (e.g., EN standards).

E 3. Maintenance checklist (see fig. 7)

The checklist must be completed by a competent person using permanent waterproof ink and must be signed by that person. The individual items to be checked must be marked with "OK" or "F" (faulty). The competent person shall be responsible for the correct nature of the information. If an "F" has been noted in the remarks, this fault can be corrected and taken away only by the competent person, that is when it concerns removal of dirt (colour, mortar, concrete) on bodies and contact areas and also when it concerns clearing of text or renewal of labels. This procedure shall be noted in the "Remarks" with date and signature of the competent person.

- C 6. It is now possible to climb the ladder. For descend, the arresting catch (fig. 7 detail 2.0) of the fall arrester must be unlocked. There are two ways of doing this:
- Lean back and thereby unlock the arresting catch
 - You are in the vicinity of the ladder and the fall arrester is hanging down. The arresting catch is unlocked by the weight of the fall arrester and remains unlocked until the person moves off evenly, i.e. without jerking.

Attention!

Before and whenever using this fall arrester, you must ensure that the locking axle (1.5) is automatically pulled in up to the stop in the housing due to the initial stress of the spring.

D Removal of the Fall Arrester from Guide Rail

Warning:

Before removing the fall arrester from the guide-rail or before disconnecting from the fall arrester at a height, protection against falls from a height must be provided by other means.

- D 1. To remove the fall arrester from the anchorage rail, the end stop (fig. 2 detail 7.0) must be passed. This is done by lifting or lowering the pivotable safety gate (fig. 2 detail 7.1) of the end stop. In case an exit device is used, the relevant instructions must be followed.
- D 2. To remove the fall arrester at any point along the route, proceed in the reverse order to the procedure for insertion described in section C 4. To do this, you must pull the locking pin on the right side of the fall arrester.

Push into the guide rail.

Fig. 4c

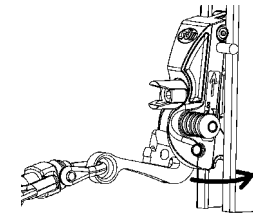

Turn the locking axle (1.5).

Fig. 4d

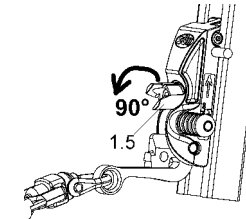

Close the shock absorber (2.0)

Fig. 4e

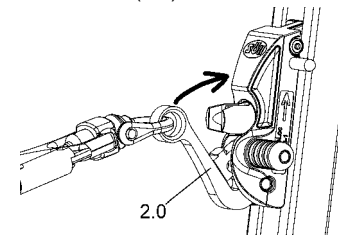

Carry out a brief functional check after the shock absorber engages.

Fig. 4f

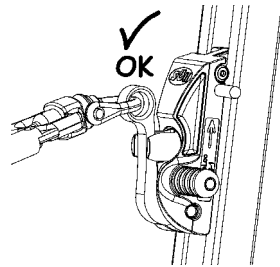

The rollers of the locking axle (1.5) must be located in the guide rail during use. The shock absorber must engage properly. In the engaged position, the shock absorber must prevent the locking axle from twisting.

To remove the fall arrester, proceed in the reverse order. To do this, you must first pull the locking pin (5.0).

Attention!

When the fall arrester "UNIVERSAL II" is used with the change over rail, the correct direction (**arrow up**) must be observed!

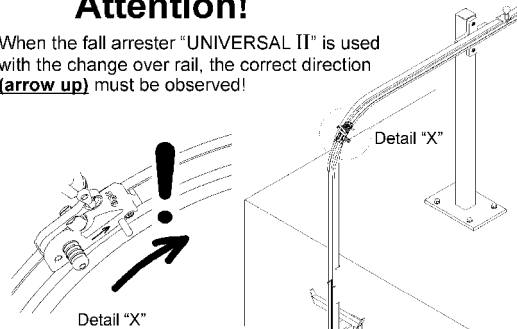
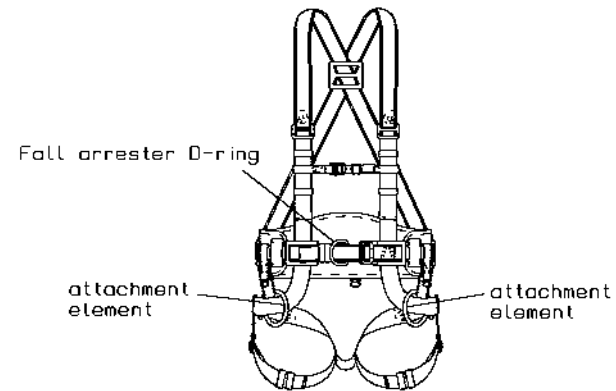

Fig. 5

Warning - risk for fatal injury!

The karabiner of the Comfort fall arrester must only be attached **directly** to the frontal D-ring of the user's harness. This requirement applies to vertical as well as horizontal use in EN 353-1 systems. The length of the connector (distance between the front face of the rail and the attachment D-ring of the users harness) must not exceed 200. (see fig. 3)

Fig. 5



C5. The abdominal or thoracic strap of the full body harness must fit the body tightly (see fig. 3).